



Glass Sliding Series



Silent



Smartness



Long-Lasting

- Fluid Glass Sliding is suitable for all types of commercial & residential areas in variant sizes.



06F Series Glass Sliding

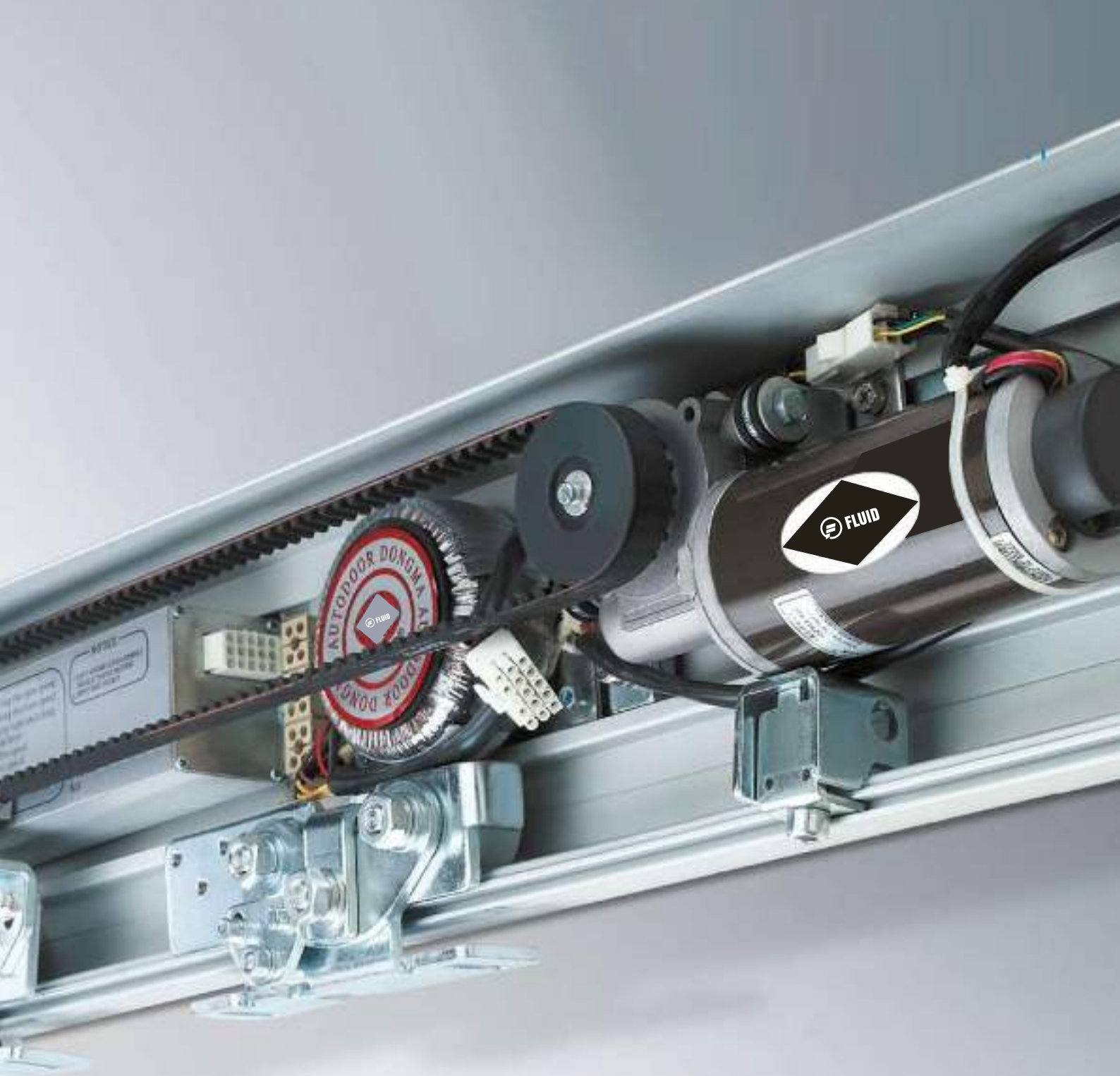

06F18001

Automatic Sliding Door System

SPECIFICATION

- Automatic Sliding Door System
- Multiple Use Commercial & Residential places
- Multiple Function with Remote Control Feature
- Smooth & Long Lasting
- Length : 4.2mtr.
- Finish : Alu.



06F Series Glass Sliding



Remote



Sensor



Timing belt



Trolley pulley, tension adjusting device



Door stopper

AUTOMATIC SLIDING DOOR SYSTEM

PRODUCTS FEATURES

The microcomputer control adopts German technology, so it can detect weight and size of the door quickly and accurately. Optimal parameters can be set for it to keep the door in the best condition. Running condition of the door can be remembered. Besides, it has adjusting function and is highly intelligent.

The remote control function, state and reliable.

the width power source, low power consumption, efficiency high performance, is stable.

Adopt brush less DC Motor and turbine worm reducer, high torque, high efficiency, long operating life.

Best humanity design, good safety, has encounter obstacles protection detection function.

Motor lock function, when door fully closed, remain closing, need not electric *switch) lock.

Half open function, can set opening position freely. Cooperate with various of access control mode.

The high quality post sale service.

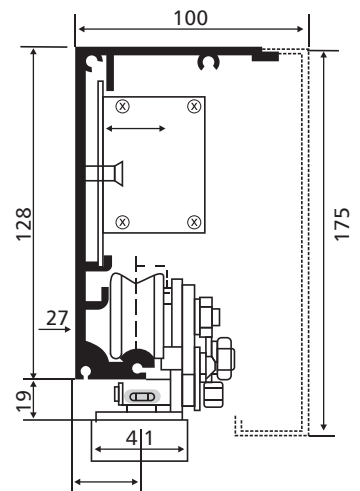

Aluminium Rail Size



Up & Down Connection Bracket



Glass clamp



Hanging group, roller and hanging parts



Control module



Motor

TECHNICAL SPECIFICATION

Type	Single Door	Double Door
Model	HD150-S	HD150-D
Loading Capacity	≤ 120KGS	≤ 2X120KGS
Power Supply	AC160-250V 50-60Hz	
Sensor Type	Compatible with sensors of various models	
DC Motor	DC 24V 2200 RPM Geared Motor (60W/90W)	
Standard Rail Length	2000mm	4000mm
Minimum Clear Width	500mm	1000mm
Maximum Clear Width	2000mm	3500mm
Opening Width	100% (Full open) / 20% (Adjustable)	
Opening Speed	100mm-500mm / sec (Adjustable)	
Closing Speed	100mm-500mm / sec (Adjustable)	
Hold Open Time	0-410 sec (Adjustable)	
Force Needed for Manual Opening and Closing	<40N	<50N
Ambient Temp	-20°C to +50°-C	



06F Series Glass Sliding

FLUID CARRIER 31 WITH DOUBLE DAMPING SYSTEM

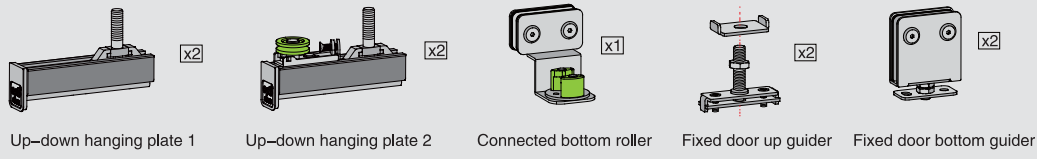
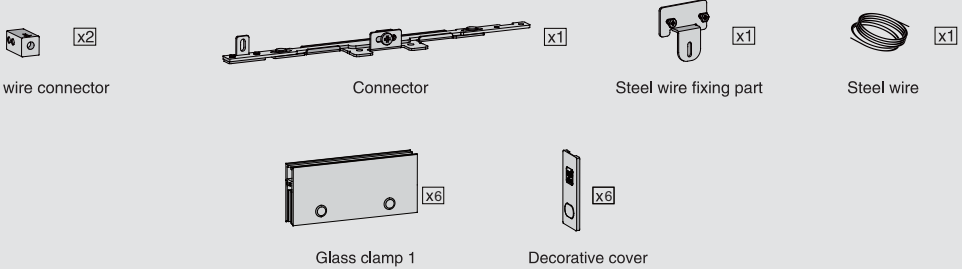
≤ 60kg

Item Code	Package Fitting (2 mobile door + 1 fixed door)
<p>2 + 1</p> <p>06F17042</p> <p>Glass Door</p>	 <p>Upper roller with damp (x2) Damp stopper (x2) Upper roller (x2) bottom roller (x1)</p>
<p>3 + 1</p> <p>06F17043</p> <p>Glass Door</p>	 <p>Up-down hanging plate 1 (x2) Up-down hanging plate 2 (x2) Connected bottom roller (x1) Fixed door up guider (x2) Fixed door bottom guider (x2)</p>
<p>4 + 1</p> <p>06F17044</p> <p>Glass Door</p>	 <p>Steel wire connector (x2) Connector (x1) Steel wire fixing part (x1) Steel wire (x1)</p> <p>Glass clamp 1 (x6) Decorative cover (x6)</p>

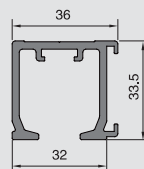
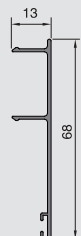
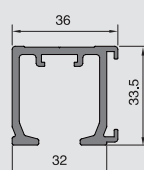
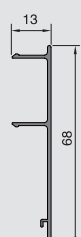
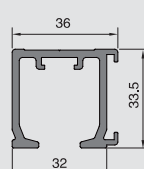
TRACKS (Pcs)

<p>06F17047</p> <p>Upper track</p> <p>2400mm</p> 	<p>06F17048</p> <p>Decorative Cover</p> <p>2400mm</p> 
<p>06F17047</p> <p>Upper track</p> <p>3600mm</p> 	<p>06F17048</p> <p>Decorative Cover</p> <p>3600mm</p> 
<p>06F17047</p> <p>Upper track</p> <p>4800mm</p> 	<p>06F17078</p> <p>Decorative Cover</p> <p>2000mm</p> 



06F Series Glass Sliding

"3 moved door+1 fixed door" as an example, the middle moved door can be increased or decreased according to your requirement.

Door height(h)=H-108mm

$$\text{Door width} = \frac{\text{door opening width}(w)}{4} + 56$$

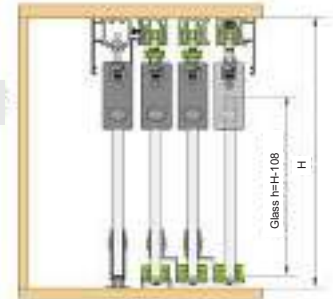
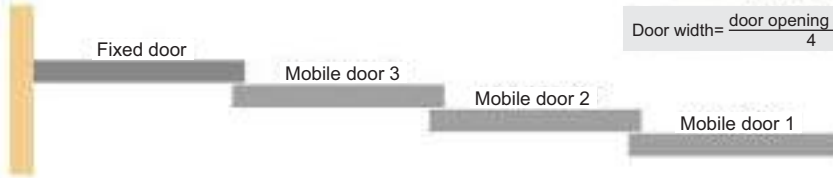

Installation steps:

1 Install up roller and stopper

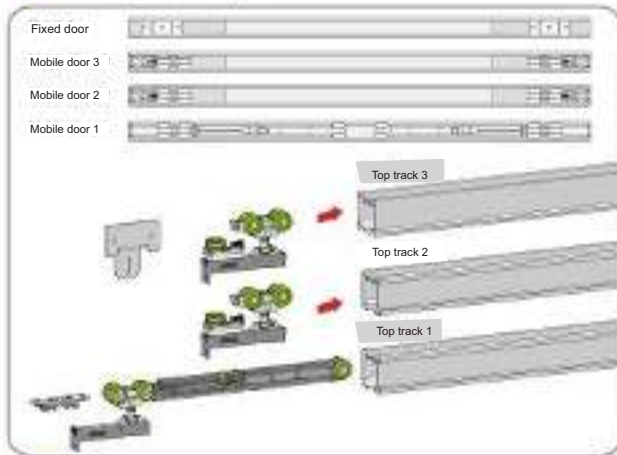

2 Install top track and bottom guider

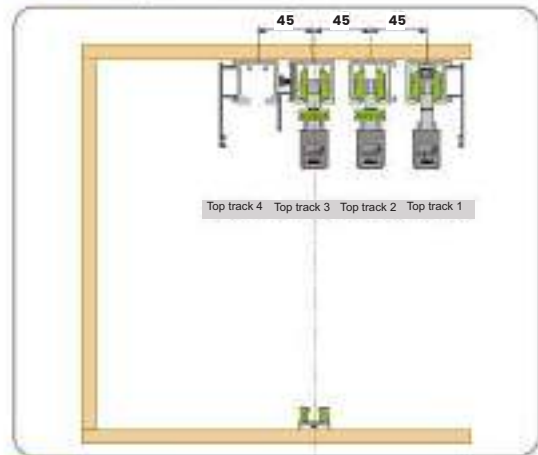

3 Install up-down hanging place

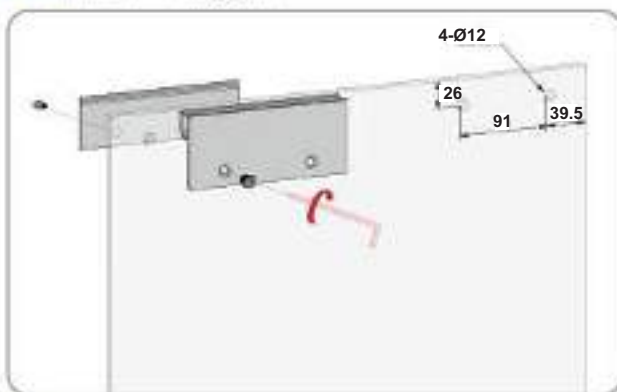

4 Install connector

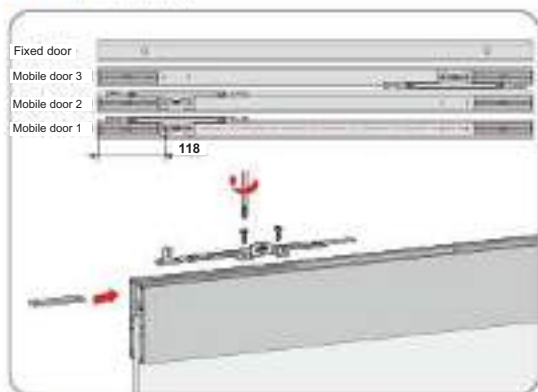

5 Install connected bottom guider

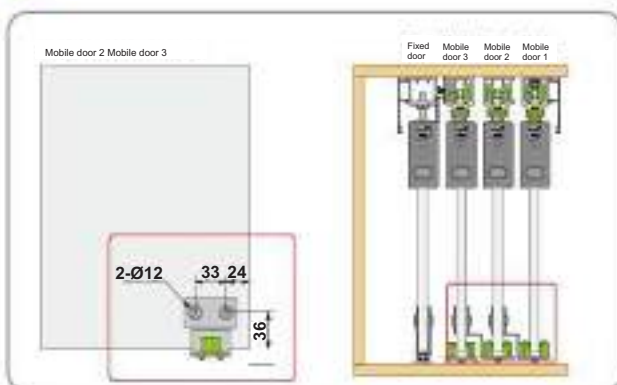

6 Install the door panels from inside to outside in turn

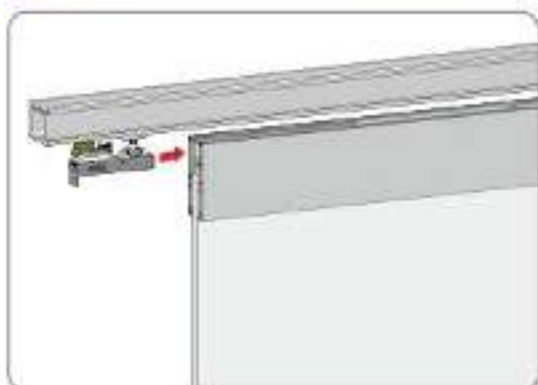

7 Winding stainless wire



Push the connector part to icon position, then fix the stainless wire

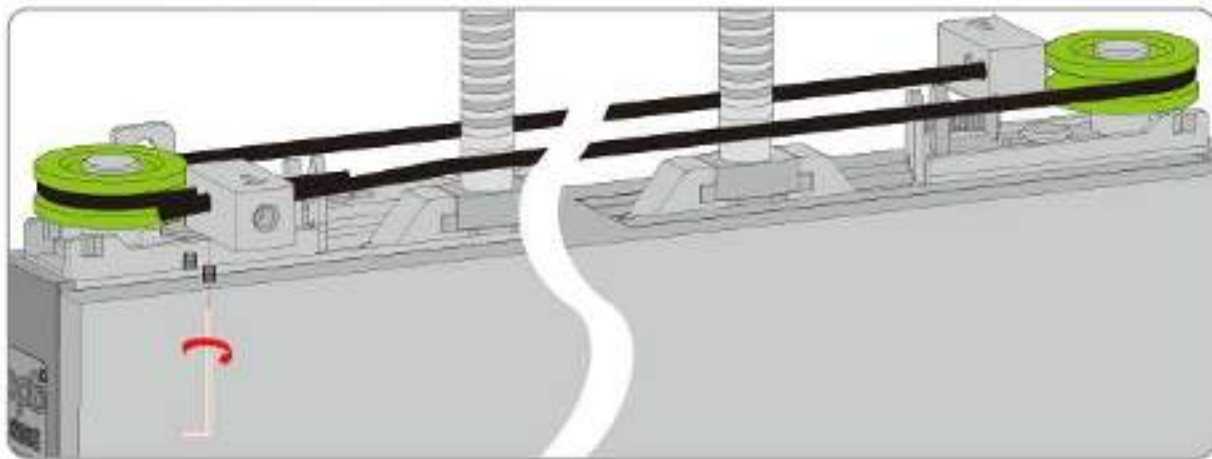

8 Fix all steel wire connector

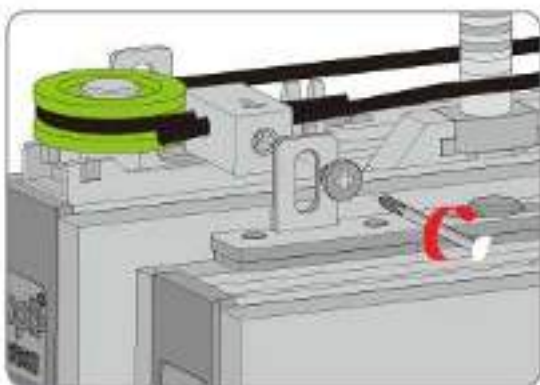

9 Fix the steel wire fixing part

Push door to the end, then fasten mounting parts on the track

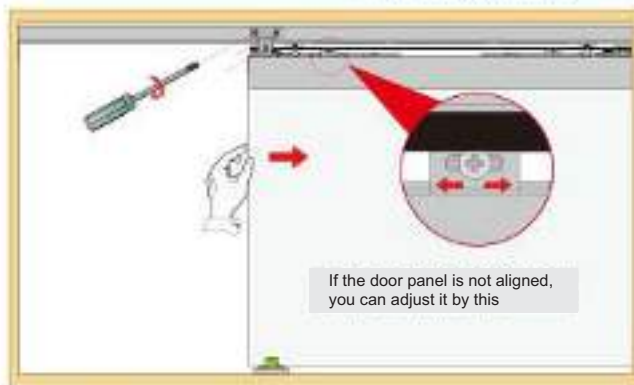

10 Install fixed door

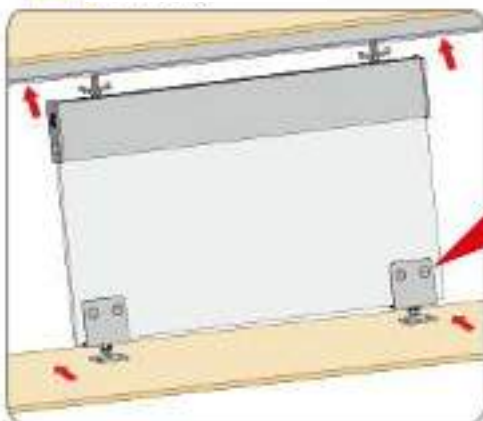

11 Installation completed

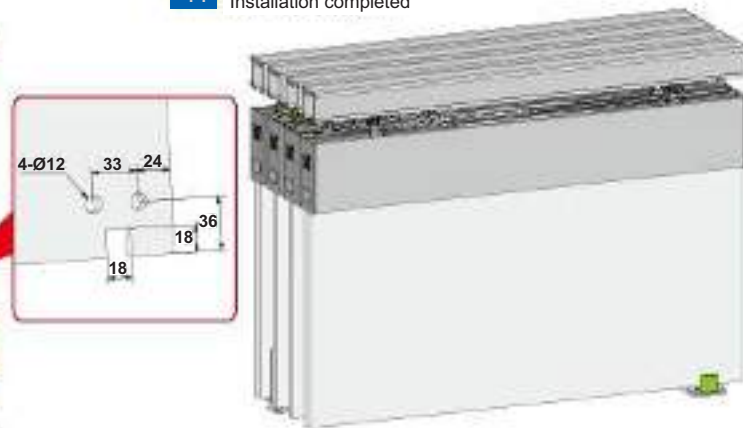

06F Series Glass Sliding

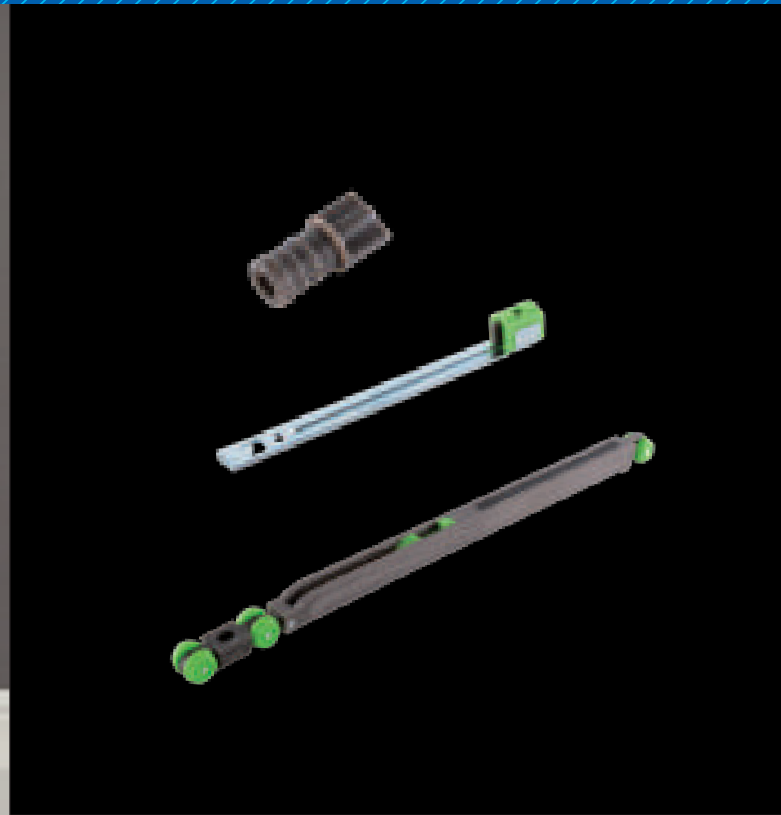

PRODUCT DESCRIPTION

- **Door up & Down adjusting device:** no need to unload door, but just use cross screwdriver to adjust door up & down
- **Smooth, steady and silent movement:** Damping function exists while door opening and door closing
- Multi Door linkage function.
- **Adjustable stopper device:** Adjustability for convenient operation; secure and steady function during door sliding.
- **Application range:** glass door
- **Glass Thickness:** 5mm

PRODUCT APPLICATION

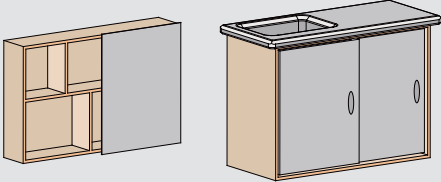
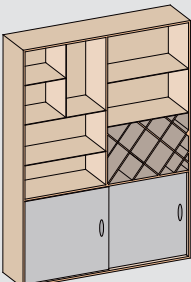
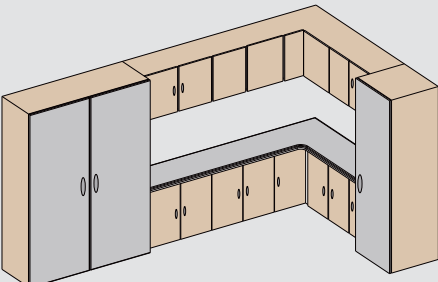
Bathroom Cabinet	Wine Cooler	Cabinet
		

FLUID CARRIER 45 WITH DOUBLE DAMPING SYSTEM (1 DOOR KIT)

≤15kg

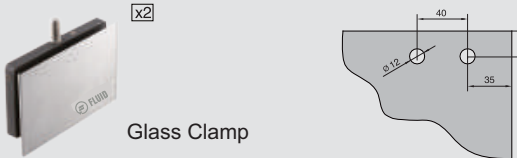
Item Code	Package Fittings
<p>06F17301 GLASS DOOR (1 Door Kit)</p>	 <p>Upper Roller with Damp (x2) Damp Stopper (x2) Bottom Guider (x1)</p>
<p>Double Damper Door Width ≥ 560mm</p>	 <p>Glass Clamp (x2)</p>



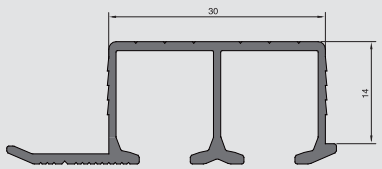
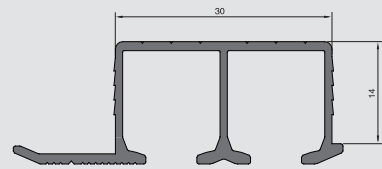

TRACKS (Pcs)

	<p>06F17302 Double Rail 3000mm</p> 
---	---

06F Series Glass Sliding

FLUID CARRIER 55 WITH DOUBLE DAMPING SYSTEM (1 DOOR KIT)

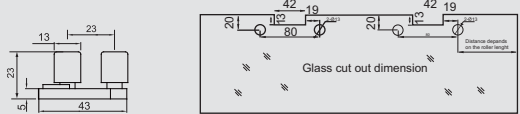
≤ 80kg

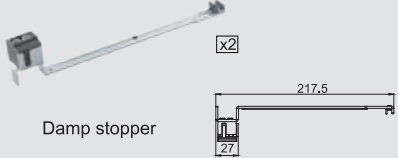
Item Code	Package Fittings		
06F17311 GLASS DOOR (One Door Kit)			
			

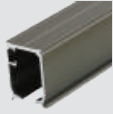
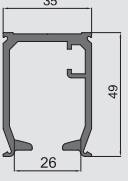
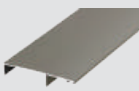
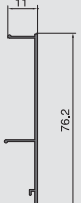
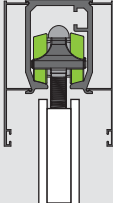

TRACKS (Pcs)

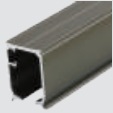
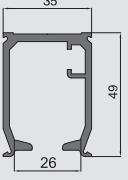
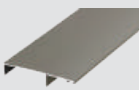
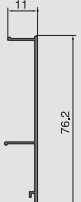
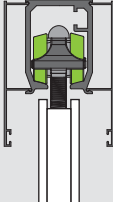
 <p>06F17036 Upper track 2400mm</p> 	 <p>06F17037 Decorative Cover 2400mm</p> 	
---	--	--

 <p>06F17036 Upper track 3600mm</p> 	 <p>06F17037 Decorative Cover 3600mm</p> 	
---	--	---

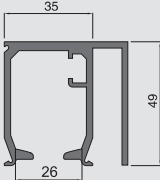
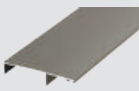
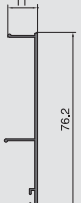
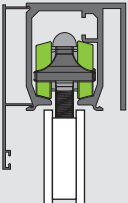
TRACKS (Pcs)

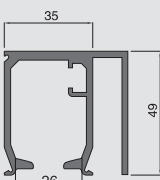
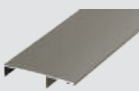
 <p>06F17038 Upper track 2400mm</p>	 <p>06F17037 Decorative Cover 2400mm</p> 	
---	--	---

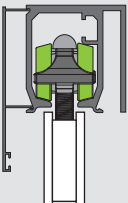





 <p>06F17038 Upper track 3600mm</p>	 <p>06F17037 Decorative Cover 3600mm</p> 	
---	--	---





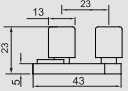
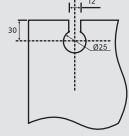

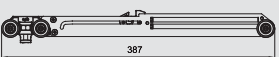
06F Series Glass Sliding

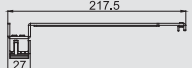
FLUID CARRIER 56 WITH DOUBLE DAMPING SYSTEM (1 DOOR KIT)



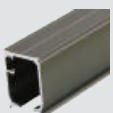

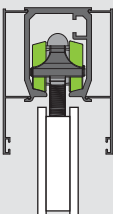
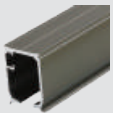
≤ 80kg

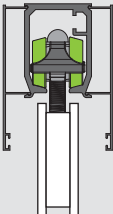
Item Code	Package Fittings			
06F17312 GLASS DOOR (One Door Kit)	 x2	 x1		 GLASS PREPARATION
	 x2 Upper Roller with Damp	 387	 x2 Damp stopper	 217.5 27

TRACKS (Pcs)

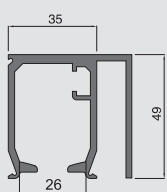
 06F17036 Upper track 2400mm	 06F17037 Decorative Cover 2400mm	
 06F17036 Upper track 3600mm	 06F17037 Decorative Cover 3600mm	

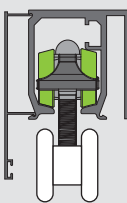
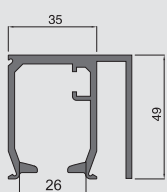
TRACKS (Pcs)

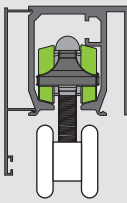
 06F17038 Upper track 2400mm	 06F17037 Decorative Cover 2400mm	
 06F17038 Upper track 3600mm	 06F17037 Decorative Cover 3600mm	

06F14101

To Mount the Track with Glass



SPECIFICATION

- Countersunk Hole for Better Holding
- Suitable to Use with 10mm & 12 Mm Glass
- Material : SS 304
- Finish : SSS

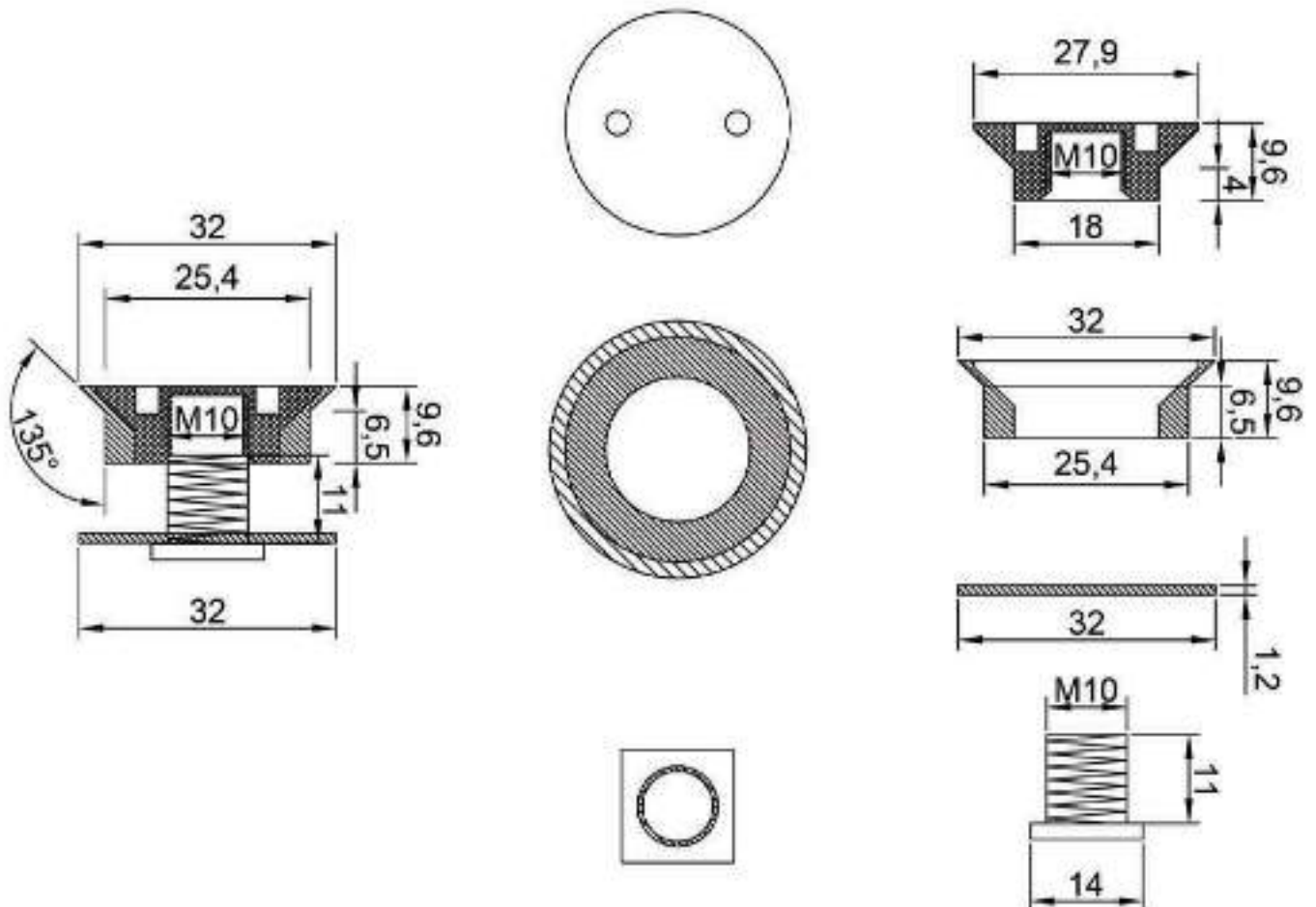

06F14102

To Hold the Track with Wall







SPECIFICATION

- Track Mounting Bracket
- Flat Face
- Material : SS 304

06F Series Glass Sliding

FLUID CARRIER 57 FOR HEAVY HANGING ROLLER (1 DOOR KIT)

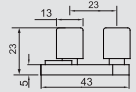
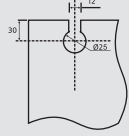
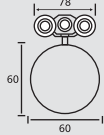
≤ 80kg



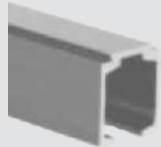
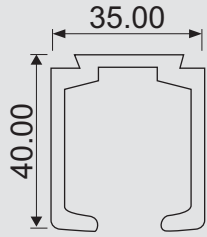
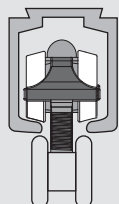
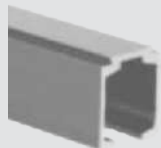
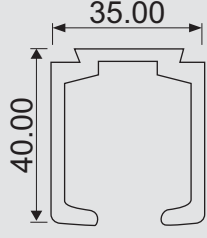
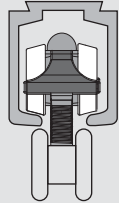
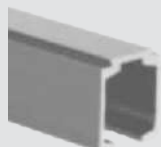
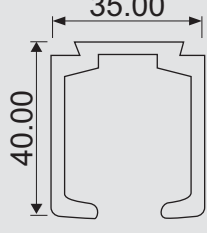
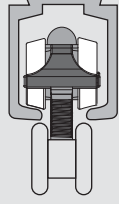

Item Code	Package Fittings			
06F17401 GLASS DOOR (One Door Kit)	 x2	 x1		 GLASS PREPARATION
			 x2	

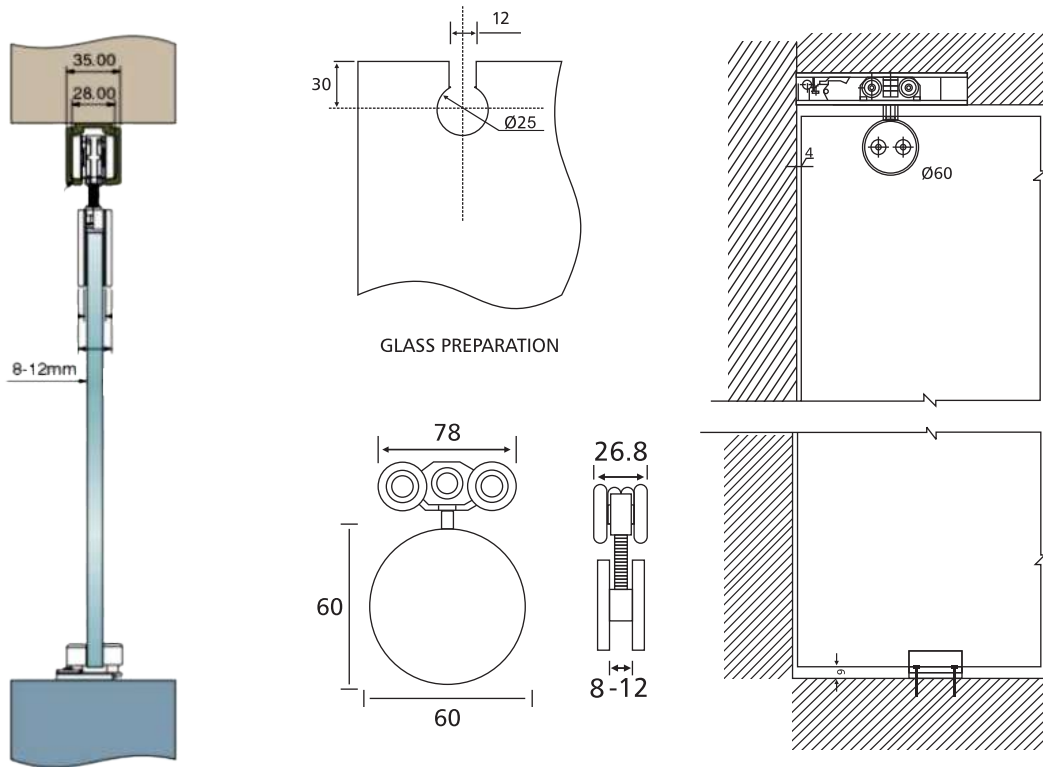
TRACKS (Pcs)

06F00113 Upper track 2400mm			
06F00113 Upper track 3600mm			
06F00113 Upper track 4800mm			

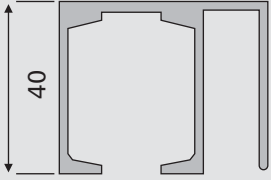
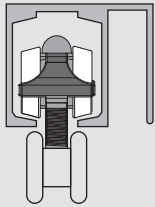

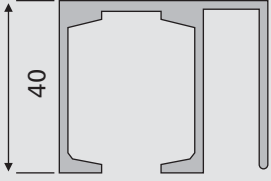
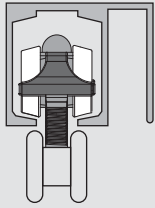
TRACKS (Pcs)

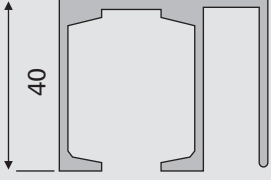
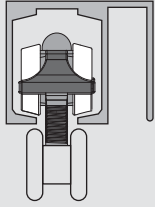
 <p>06F00114 Upper track 2400mm</p>	 <p>40</p>	
 <p>06F00114 Upper track 3600mm</p>	 <p>40</p>	
 <p>06F00114 Upper track 4800mm</p>	 <p>40</p>	



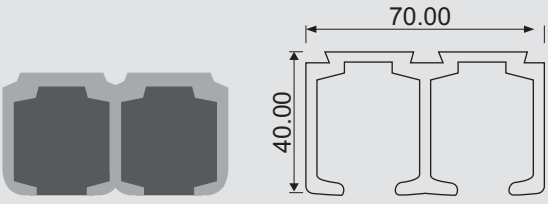
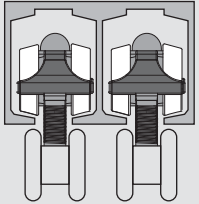
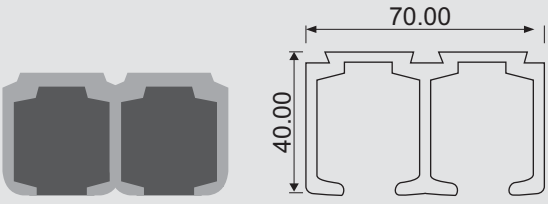
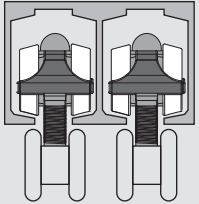
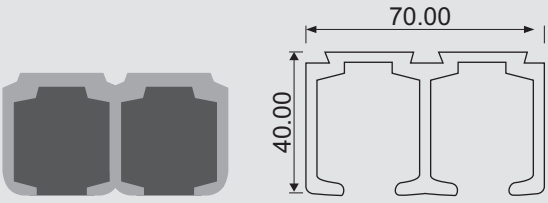
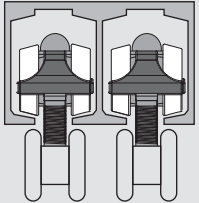

06F Series Glass Sliding

TRACKS (Pcs)

<p>06F00115 Upper track 2400mm</p>		
<p>06F00115 Upper track 3600mm</p>		
<p>06F00115 Upper track 4800mm</p>		

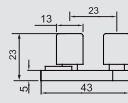
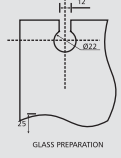
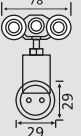

FLUID CARRIER 58 FOR HEAVY HANGING ROLLER (1 DOOR KIT)

≤ 80kg

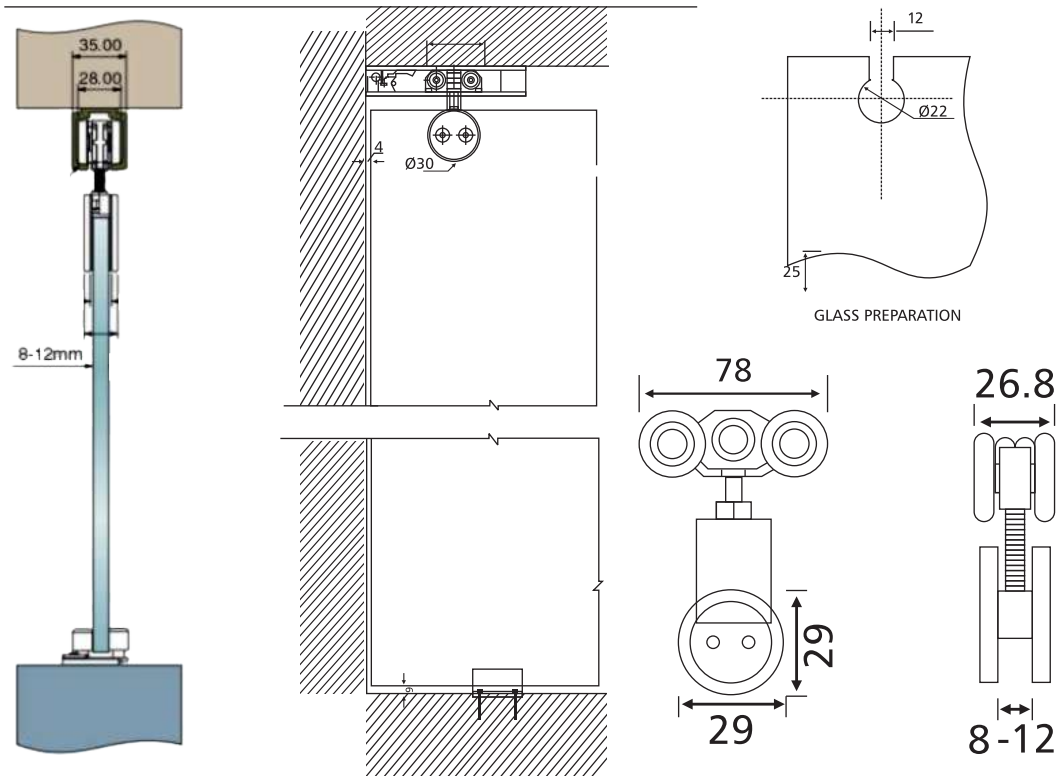
Item Code	Package Fittings			
<p>06F17402 GLASS DOOR (One Door Kit)</p>				 <p>GLASS PREPARATION</p>
				



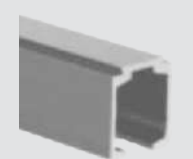
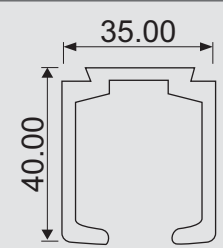
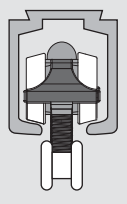
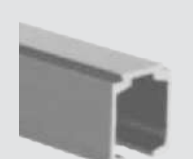
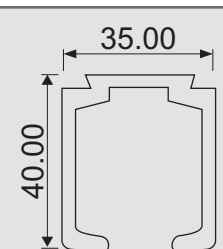
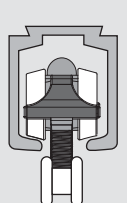

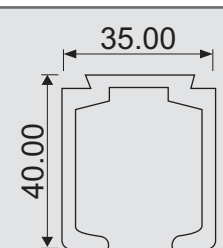
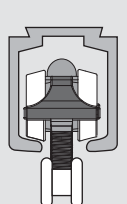

TRACKS (Pcs)

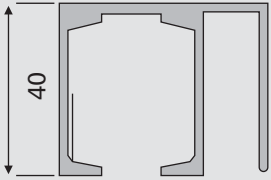
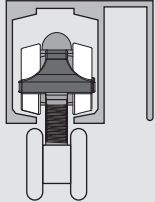

<p>06F00113 Upper track 2400mm</p>			
<p>06F00113 Upper track 3600mm</p>			
<p>06F00113 Upper track 4800mm</p>			

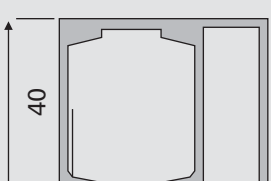
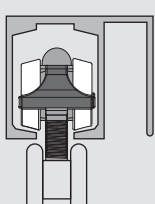
06F Series Glass Sliding

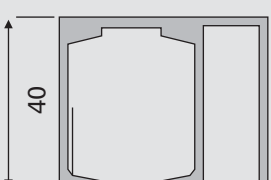
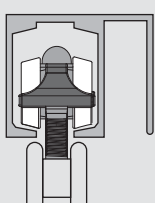
TRACKS (Pcs)

 <p>06F00114 Upper track 2400mm</p>		
 <p>06F00114 Upper track 3600mm</p>		
 <p>06F00114 Upper track 4800mm</p>		

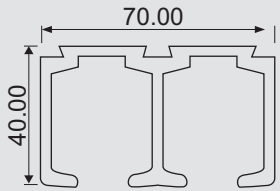
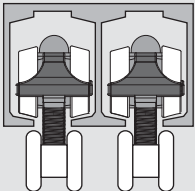
TRACKS (Pcs)

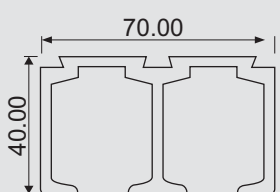
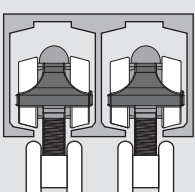
<p>06F00115 Upper track 2400mm</p>	 	
<p>06F00115 Upper track 3600mm</p>	 	
<p>06F00115 Upper track 4800mm</p>	